



CONTENTS - CHAPTER 4

This chapter covers the 4th pull down menu set.

This chapter covers the 4 th pull down menu set.	2
1. The first option is the LOD (Letters of Demand)/ N.C.A. (National Credit Act) Sec129.	4
1.1 Letter of demand Posted Option.	4
1.2 The Returned to Sender (RTS).	5
1.3 Registered Mail Control List.	5
2. This option is the AOD (Acknowledgement of debt) Documents.	6
2.1 Posted to Debtor.	6
2.2 Received from Debtor	6
2.3 Returned UN - Signed.	7
3. This option is the Summons Documents.	7
Summons to Court.	7
3.2 Summons from Court.	8
3.3 Summons to Sheriff.	8
3.4 Summons Return Query (from Sheriff).	8
3.5 Return of Service.	9
3.5 Summons Control List.	10
4. This option is Application for default judgment.	10
4.1 Application for Default judgment To Court.	10
4.2 Application for Default judgment from Court.	11
4.3 Judgment Control List.	11
5. This option is the Consent to judgment Sec. 58.	12
This option is still to follow.	12
6. This option is the Consent to judgment Sec. 58.	12
This option is still to follow.	12
7. List of Figures for Chapter 4.	13



NAMES AND ADDRESSES OR ANY OTHER REFERENCE TO PERSONS OR ENTITIES LIVING OR DEAD IS PURELY COINCIDENTAL. NO TRUE OR REAL DATA IS OR HAS BEEN USED; THE DATA HAS BEEN CREATED TO REPRESENT WHAT REAL DATA WOULD LOOK AND FUNCTION THROUGH THE FUNCTIONS OF THIS PROGRAM. GEOGRAPHICAL AREAS AND REGIONAL NAMES ARE CORRECT, AS ARE THE CODES AND GOVERNMENT ENTITIES THEIR IN. SOME FICTITIOUS AREAS AND NAMES ARE USED FOR TRAINING AND EXPLANATIONS FUNCTIONS OR PURPOSES.

Clicking the **Document Tracking** button as shown below in the file menu opens the drop down menu.



Figure 1 File Menu Options, Document Tracking

The drop down menu looks like this.

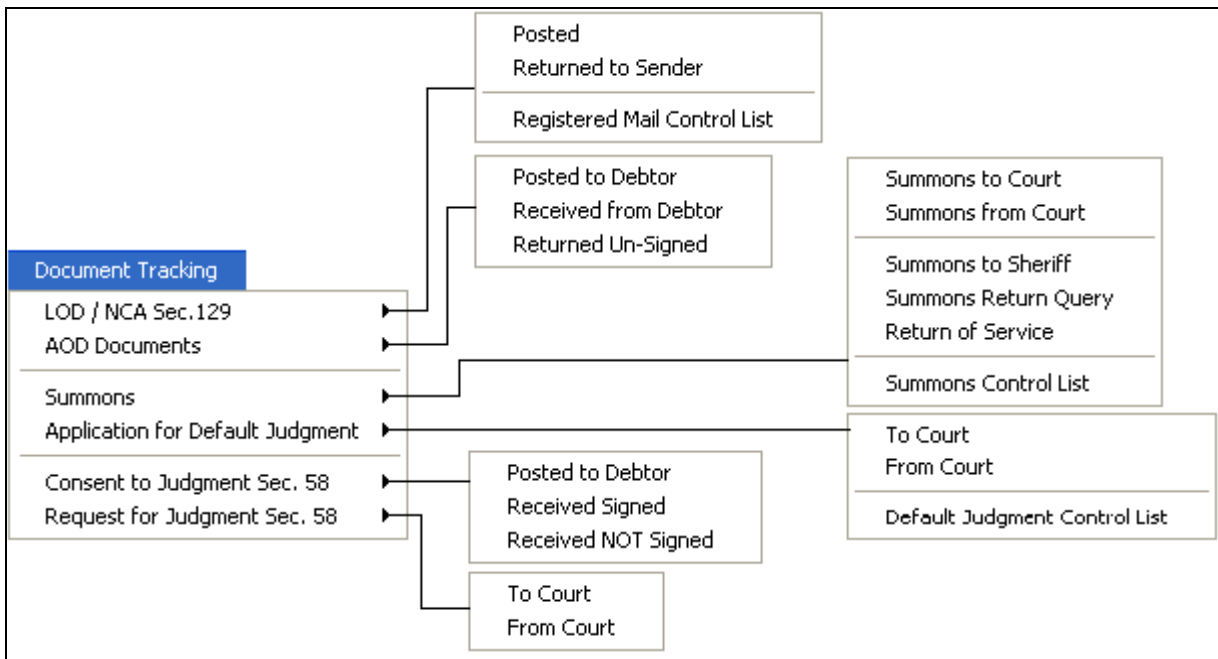

Figure 2 Document Tracking Menu

1. The first option is the LOD (Letters of Demand)/ N.C.A. (National Credit Act) Sec129.

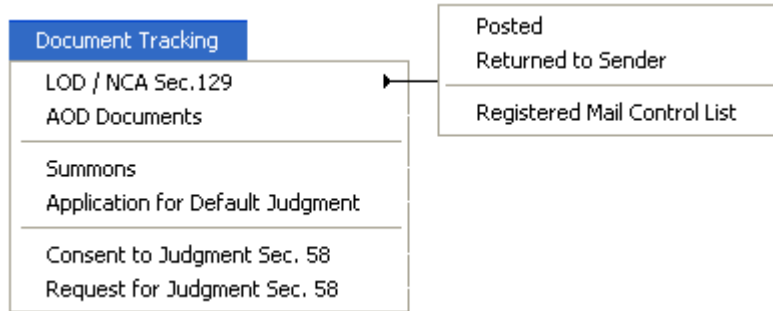

Figure 3 Document Tracking Drop Down Menu

1.1 Letter of demand Posted Option.

The Final Demand document that will be generated will depend on the type of collection that was chosen when the file was created. (Generic Final Demand / School Fees Final Demand)

Select the Posted option to open the Letter of Demand Posted. Enter the file number or Click the *Open File icon* to help select the right file number. See the lookup entry form below.



Figure 4 Letter Of Demand Posted

Select the N.C.A or Letter of Demand option by Clicking with the mouse on your selection. The software will require the method by which the final demand will be sent. This is to keep record of the action made and add and applicable costs such as registered mail costs.

Click the sent by registered mail icon if using this method of posting, then scan the bar code of the tracking sticker.

Click the Add button. This action will be recorded in the Actions Taken List on the main screen.

Click the Exit button to exit without saving any changes.

The lookup entry form allows you to look for the correct file number. The defendant /debtor you are working with has a unique number. This is the number to use for the new actions you are adding to the record.

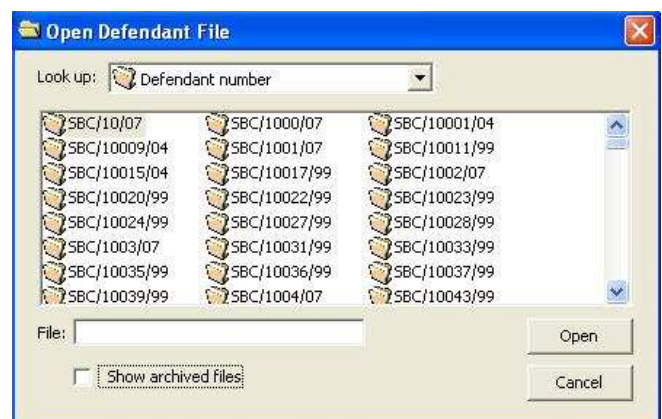

Figure 5 Open Defendant File menu

1.2 The Returned to Sender (RTS).

This is the Return to Sender form.



Figure 6 RTS Reasons Form

This form is filled in to record the reason for the Letter of Demand being returned.

Open the file number by selecting the *Open File icon* then select the correct file number.

☞ *Click* the box next to the reason given from the post office RTS sticker.

☞ *Click* **Add** button. This action will be recorded in the Actions Taken List on the main screen.

☞ *Click* **Exit** button to exit without saving any changes.

1.3 Registered Mail Control List.

This is the Registered mail control list. Use this to check the status of the Letters of Demand that have been sent out.

Enter a registered letter bar code or scan the stub from the manual list. The status is displayed.

☞ *Click* the **Clear List** button to clear displayed data.

☞ *Click* **Print** button to print to printer. The registered mail status for the selected mail will print.

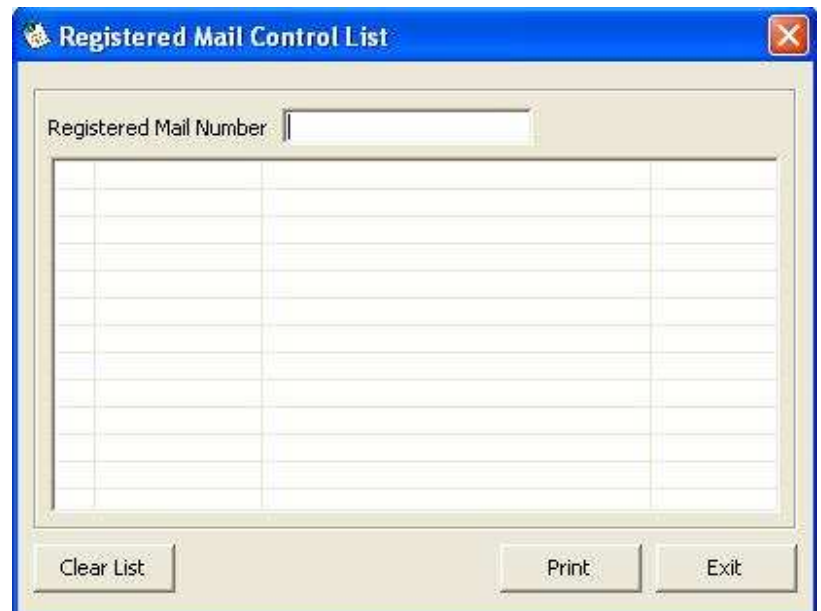

Figure 7 Registered Mail Control List.

2. This option is the AOD (Acknowledgement of debt) Documents.

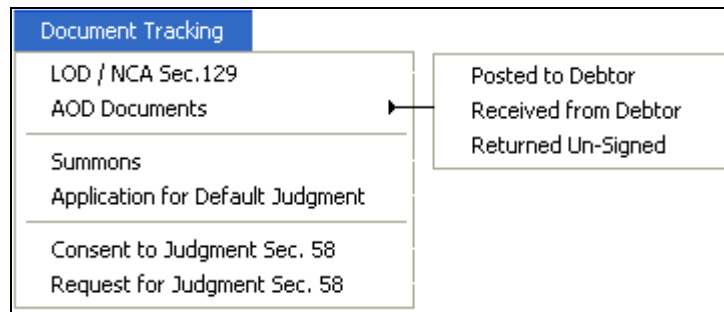

Figure 8 Document Tracking Pull down Menu AOD Options

2.1 Posted to Debtor.

Select the Posted to Debtor option to open the AOD (Acknowledgement of debt) Posted form. Enter the file number or Click the *Open File icon* to help select the right file number.



Only perform this step if the AOD has been posted.

This form records that the acknowledgement of debt has been sent.



Figure 9 Posted To Debtor

Click button. This action will be recorded in the Actions Taken List on the main screen.

Click button to exit without saving any changes.

2.2 Received from Debtor

Select the Received from Debtor option to open the AOD Signed form. Enter the file number or Click the *Open File icon* to help select the right file number.



Only perform this step if the AOD has been signed.

This form records that the acknowledgement of debt has been signed.



Figure 10 AOD Received from Debtor

Click button. This action will be recorded in the Actions Taken List on the main screen.

Click button to exit without saving any changes.

2.3 Returned UN - Signed.

Select the Received from Debtor option to open the AOD NOT Signed form. Enter the file number or  Click the *Open File icon* to help select the right file number.



Only perform this step if the AOD has been NOT been signed.

This form records that the acknowledgement of debt has been not been signed.

Figure 11 RTS UN Signed.

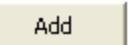
 Click  button. This action will be recorded in the Actions Taken List on the main screen.

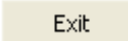
 Click  button to exit without saving any changes.

3. This option is the Summons Documents.

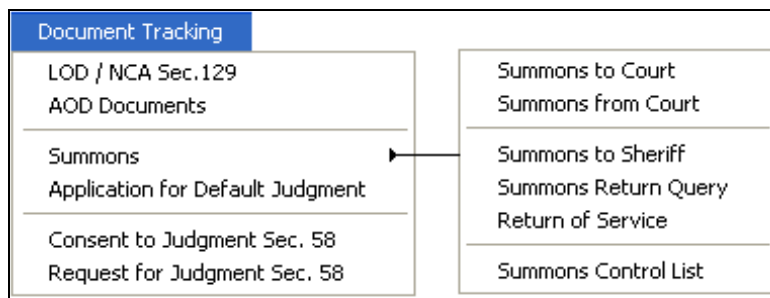



Figure 12 Summons Drop Down Menu

Summons to Court.

Select the Summons to Court option to open the Summons to Court form. Enter the file number or  Click the *Open File icon* to help select the right file number.

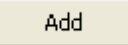

Only perform this step if the Summons to Court has been completed.

 Click  button.

This action will be recorded in the Actions Taken List on the main screen.

 Click  to exit without saving any changes.

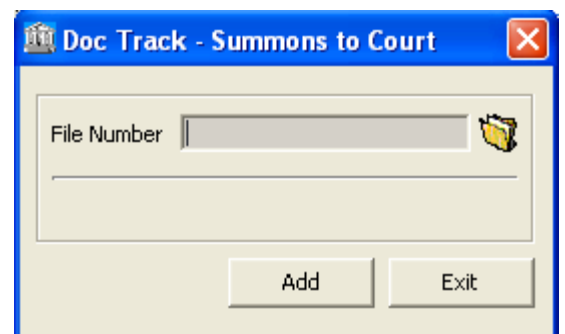



Figure 13 Summons to Court

3.2 Summons from Court.

Select the Summons from Court option to open the Summons from Court form.
Enter the file number or  Click the *Open File icon* to help select the right file number.



Only perform this step if the Summons from Court has been completed. The case number must be entered.

Remember to scan the court document. This action will be recorded in the Actions Taken List on the main screen.

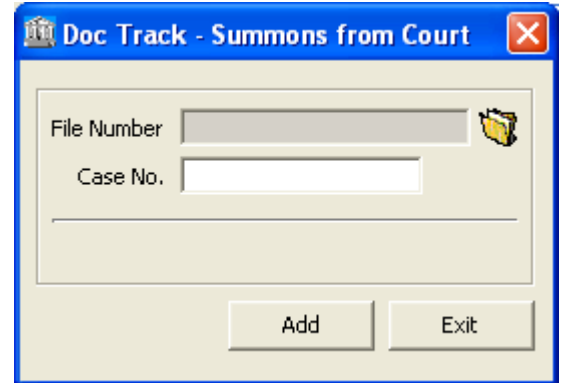







Figure 14 Summons from Court

3.3 Summons to Sheriff.

Select the Summons from Court option to open the Summons from Court form. Enter the file number or  Click the *Open File icon* to help select the right file number.



Enter the sheriff for the area where the summons is being served.

 Click  button.
This action will be recorded in the Actions Taken List on the main screen.
 Click  to exit without saving any changes.

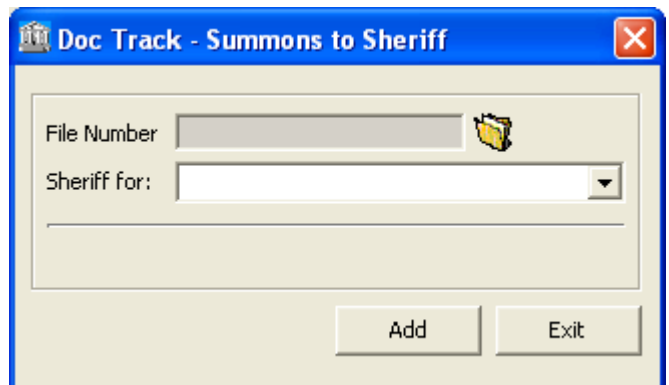

Figure 15 Summons to Sheriff

3.4 Summons Return Query (from Sheriff).

The status of Summonses is updated from this form.

Select the Summons Service Verify option to open the Summons Service Verify form.

Click  the drop down menu arrow to select from the pre-defined list of available Area's.

Select the area of interest, to view all the matters for that area's Sheriff office.

 Remember the area is where the summons is served.

- Click the options to view
- No FOLLOW- UP.
 - SERVED
 - NOT SERVED summonses for that Sheriff Office.

Click to select the UN-RETURNED button for the report to view all summonses that have not been returned from the Sheriff for that area.

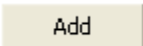
Click  button.

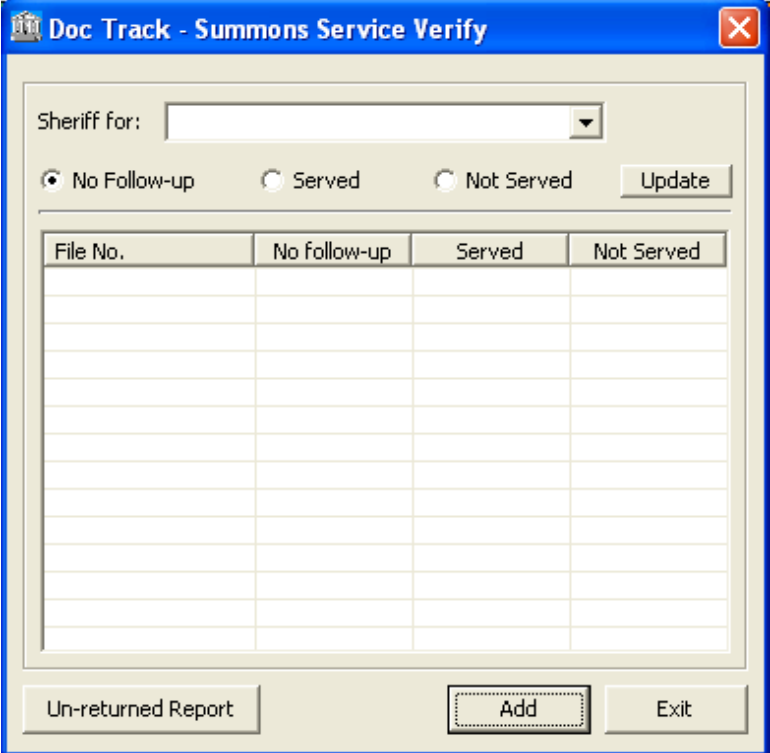

File No.	No follow-up	Served	Not Served

Figure 16 Summons Service Verify Form

This action will be recorded in the Actions Taken List on the main screen.

Click  to exit without saving any changes.

3.5 Return of Service.

The status of Summonses is updated from this form.

Select the Summons From Sheriff option to open the Summons From Sheriff form.

Select the Summons from Sheriff option to open the Summons from Sheriff form. Enter the file number or
Click the *Open File icon* to help select the right file number.

 Enter the date the Summons was served or was attempted.

Click the Served YES or NO option and add the cost for the service.

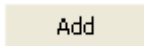
Click  button. This action will be recorded in the Actions Taken List on the main screen.

Click  to exit without saving any changes.

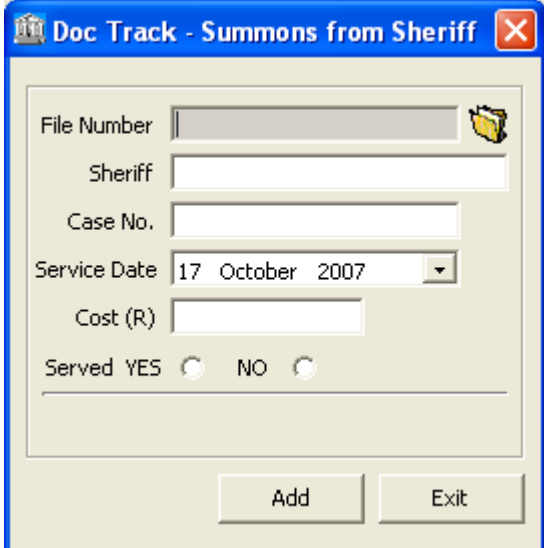



Figure 17 Summons Return Service

3.5 Summons Control List.

This is the Summons control list.

Enter a file number. The status is displayed for that file.

Use the  button to clear displayed data.

Click  button to print to printer. The Summons status for the selected file will print.

Click the  button to exit.

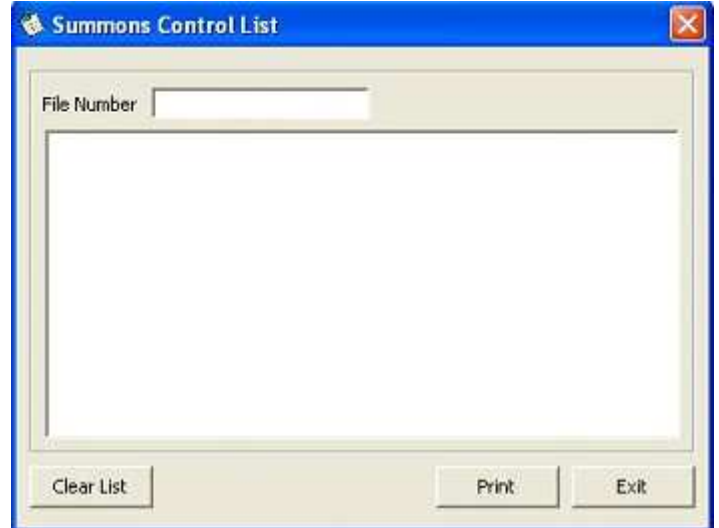

Figure 18 Summons Control List

4. This option is Application for default judgment.

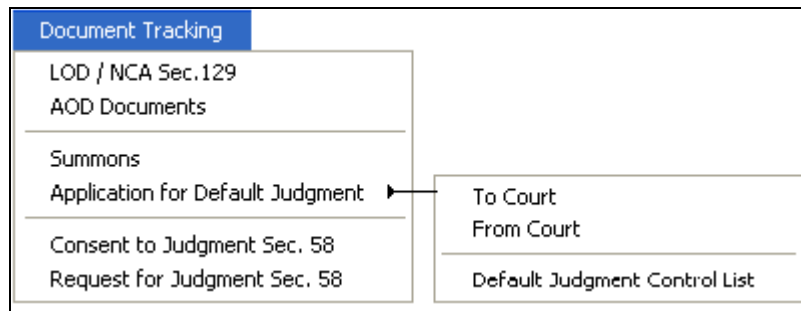

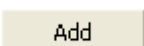

Figure 19 Default Judgment Drop Down Menu

4.1 Application for Default judgment To Court.

Select the Judgement to Court option to open the Judgement to Court form. Enter the file number or Click the *Open File icon* to help select the right file number.

 Only use this option if the matter is being set to court for application for default judgement.

Click  button. This action will be recorded in the Actions Taken List on the main screen.

Click  to exit without saving any changes



Figure 20 Default Judgment To Court

4.2 Application for Default judgment from Court.

Select the Judgement from Court option to open the Judgement from Court form. Enter the file number or  Click the *Open File icon* to help select the right file number.

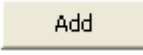

Enter the date the Judgment was set. Add the amount of the Judgment awarded. Remember to scan the court document.

 Click  button. This action will be recorded in the Actions Taken List on the main screen.

 Click  to exit without saving any changes.

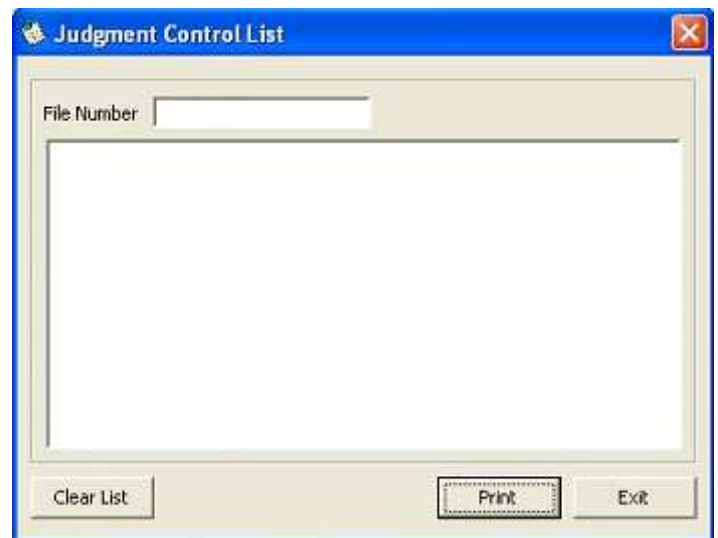



Figure 21 Judgment from Court.

4.3 Judgment Control List.

This is the Judgment control list.

Enter a file number. The status is displayed for that file.

Use the  button to clear displayed data.

 Click  button. This action will be recorded in the Actions Taken List on the main screen.

 Click  button to exit.

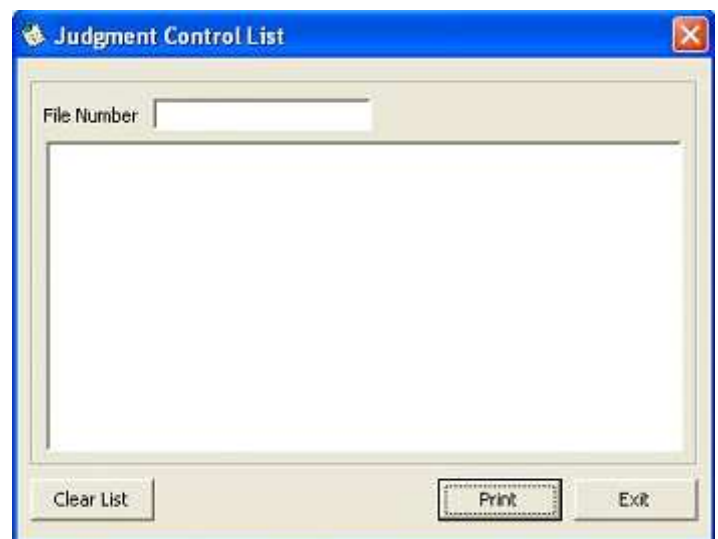

Figure 22 Judgment Control List

5. This option is the Consent to judgment Sec. 58.

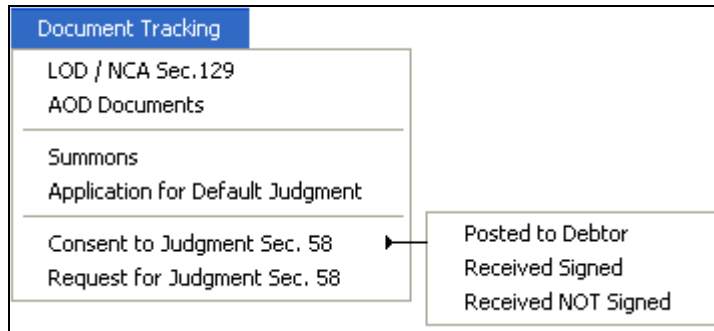

Figure 23 Document Tracking Drop Down Menu

This option is still to follow.

6. This option is the Consent to judgment Sec. 58.

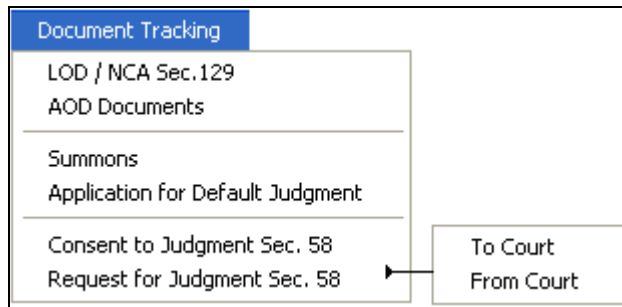

Figure 24 Request For Judgment

This option is still to follow.

7. List of Figures for Chapter 4.

FIGURE 1 FILE MENU OPTIONS, DOCUMENT TRACKING	3
FIGURE 2 DOCUMENT TRACKING MENU	3
FIGURE 3 DOCUMENT TRACKING DROP DOWN MENU	4
FIGURE 4 LETTER OF DEMAND POSTED	4
FIGURE 5 OPEN DEFENDANT FILE MENU	4
FIGURE 6 RTS REASONS FORM	5
FIGURE 7 REGISTERED MAIL CONTROL LIST.	5
FIGURE 8 DOCUMENT TRACKING PULL DOWN MENU AOD OPTIONS	6
FIGURE 9 POSTED TO DEBTOR	6
FIGURE 10 AOD RECEIVED FROM DEBTOR	6
FIGURE 11 RTS UN SIGNED.	7
FIGURE 12 SUMMONS DROP DOWN MENU	7
FIGURE 13 SUMMONS TO COURT	7
FIGURE 14 SUMMONS FROM COURT	8
FIGURE 15 SUMMONS TO SHERIFF	8
FIGURE 16 SUMMONS SERVICE VERIFY FORM	9
FIGURE 17 SUMMONS RETURN SERVICE	9
FIGURE 18 SUMMONS CONTROL LIST	10
FIGURE 19 DEFAULT JUDGMENT DROP DOWN MENU	10
FIGURE 20 DEFAULT JUDGMENT To COURT	10
FIGURE 21 JUDGMENT FROM COURT.	11
FIGURE 22 JUDGMENT CONTROL LIST	11
FIGURE 23 DOCUMENT TRACKING DROP DOWN MENU	12
FIGURE 24 REQUEST FOR JUDGMENT	12